

» Electrical

Actuators - Powermaster



» Powermaster

» Product Summary

- Powerful 300N, 230v and 24v actuator
- Strong double link chain
- Choice of 380mm, 660mm or 860mm (24v only) strokes
- Other strokes available subject to special order
- Supplied complete with pivot brackets
- Bottom hung fixing brackets available seperately
- Supplied with 1.5m cable

» Standard Colours

Silver Anodised

*Classified in accordance with EN 60034 - (duty cycle)

**Only with suitable approved control devices, ensure total current consumption does not exceed that of the control system output.

Control system must ensure a 1-2 second volt-free period is allowed for when changing direction

» Additional Information

Dimensions

Stroke	380	660	860
230v			
Overall Length A	626	768	
Offset B	277	418	
24v			
Overall Length A	473	613	713
Offset B	277	418	517

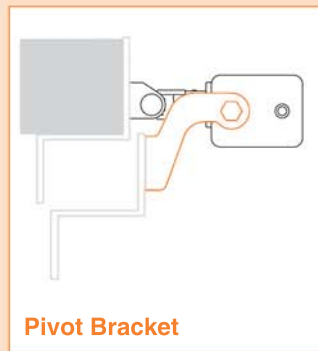
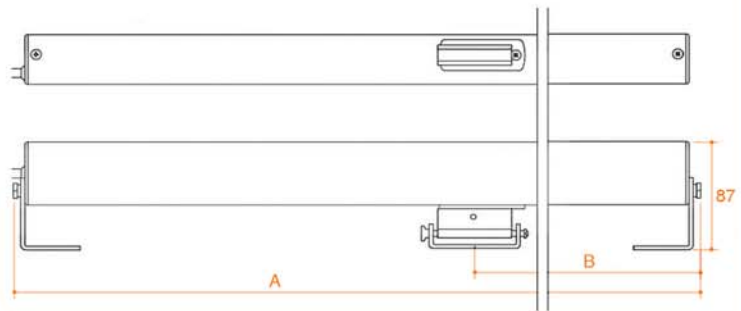

Pivot Bracket

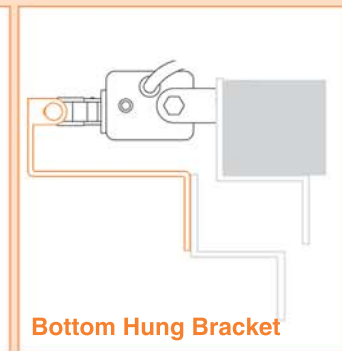

Bottom Hung Bracket

» Technical Specification

Voltage	24V dc	230V ac
Stroke	380 / 660 / 860 mm	380 / 660mm
Thrust Force	300N	300N
Absorbed Current	1A	0.50A
Speed	18mm/s	18mm/s
Protection Class	IP32	IP32
Wiring	4 Core	4 Core
Colours Available	Silver anodised	Silver anodised
Limit Stop	Microswitch	Microswitch
Safety Stop	Electronic	Electronic

Actuators - Powermaster

OPERATION

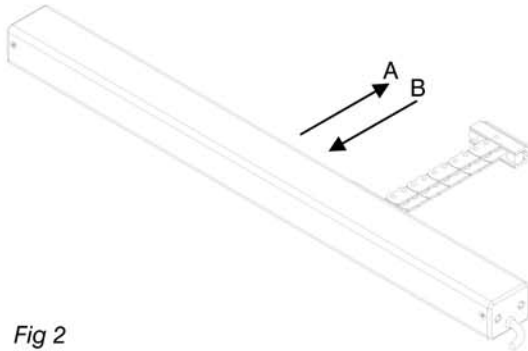

Fig 2

Operation of the actuator is achieved by applying a 230v AC supply to the BROWN & BLACK cores of the flex:

Applying 230v to the BLACK will drive the chains outwards (fig 2 A).

Applying 230v to the BROWN will drive the chains inwards (fig 2 B).

Partial opening is achieved by removing the 230v supply part way through the open or close operation, this will stop the chains where they will remain until the 230v supply is re-applied. Ensure there is a minimum of 1-2 seconds volt-free 'off' period between any changes of direction.

It is recommended the controlling circuit is operated by contactors for groups of actuators with a quantity greater than 4. Relay contacts if used should be capable of withstanding an inrush current of

The power supply must not be left on for extended periods of time, see below for details. The supply for the actuators must switch from open to close by means of a simple change-over relay circuit, as this will not provide the 'off' times required by these actuators. The controlling circuit must ensure the supply is switched off during idle periods.

Notes on Duty Cycle

Electric chain actuators have a limited duty cycle that specifies how often and for how long they are operated in a given time period. This is to ensure that they are not overloaded which can result in overheating and excessive wear and tear. In extreme cases the actuators will burn out.

Duty cycles are typically quoted in accordance with EN60034.

This particular model is rated at S2 20%. See below for further information:

Fig 3

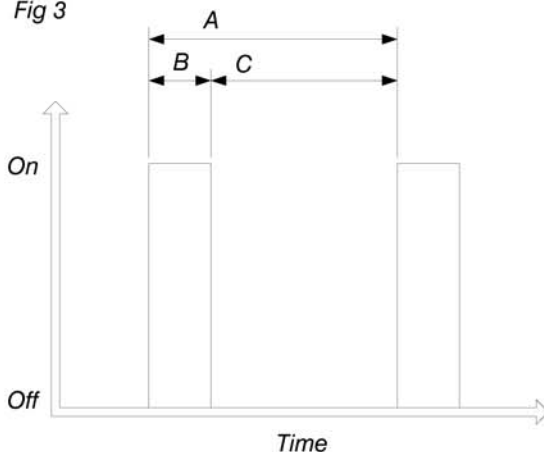

Fig 2 shows a duty cycle of S2 20%

Where;

A = Cycle time

B = Operating time

C = Rest 'Off' period

During a stroke period of approximately 1 minute the actuator should have a rest or 'off' period of approximately 4 minutes before any further operations.

Operating from Building Management Systems

Where chain actuators are controlled from Building Management Systems (BMS) care is required to ensure excessive 'hunting' by the control system is prevented. This is often the case when the BMS system is set to modulate the opening of the actuators in an attempt

to control temperature too closely. This type of excessive control will invariably exceed the actuators duty cycle and shorten the life time of the actuators. This can be reduced by increasing the temperature set point 'dead bands' and applying a set time period between temperature samples.

BMS systems can utilise timed operations to achieve partial openings. Because some actuators may run at very slightly different speeds, many partial operations can result in the actuators being open varying amounts. It is advised that every 5 or so partial operations, a full close is implemented (close control for full time of actuator stroke plus a few seconds), this will ensure any 'drift' in actuator positions is kept to a minimum.

MAINTENANCE

Functional testing at regular intervals, if the actuators form part of a smoke ventilation system, refer to the maintenance guidelines for the system.

Actuators are supplied with a lubricated chain, this may require periodic inspection to ensure the chain remains sufficiently coated.

Inspection of fixings and actuator pivot bolts, tightening any loose parts. Ensure all pins and retaining clips are secured.